

# POWERING WIRELESS SENSORS FOR ROTORCRAFT HUMS

**Steve Burrow**

With thanks to:

**James Bowden, Lindsay Clare, Dan Wells, Dan Hewitt, Pia Sartor**



# Overview

- What are HUMS?
- Wireless HUMS prototypes
- Comparison of battery storage with harvested vibration energy





# Maintenance philosophies

- Run to failure
  - *keep operating until failure*
- Time based maintenance
  - *Inspect/maintain after so long or so many cycles*
- Condition based maintenance
  - *Measure/monitor continually*



# 🔥 What are HUMS?

Health and Usage Monitoring Systems are used to implement autonomous condition based maintenance.

HUMS attempt determine the state of a component or structure (diagnosis) from measurable parameters

The 'holy grail' of the discipline to perform prognosis - i.e. to predict remaining lifetime of components

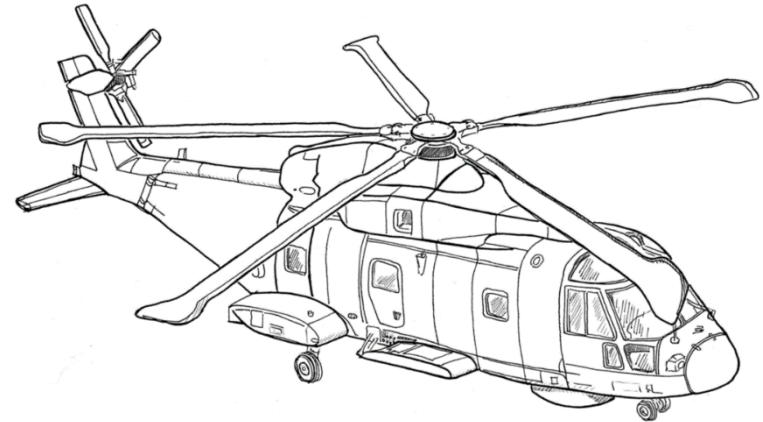

# NEWS NE SCOTLAND, ORKNEY & SHETLAND

Home World UK England N. Ireland Scotland Wales Business Politics Health Education Sci/Environment Technology Entertainment & Arts

Scotland Decides Politics Business Edinburgh, Fife & East Glasgow & West Highlands & Islands NE, Orkney & Shetland South Tayside & Central

23 October 2012 Last updated at 16:00



## CHC, Bristow and Bond helicopters halt some flights after ditching



SIMON TRANBERG/VAMMEN

The first pictures of the ditched helicopter have emerged

**All three operators of North Sea offshore helicopters have grounded the type of aircraft involved in Monday's ditching off Shetland.**

A Super Puma EC 225, operated by CHC, carried out a controlled landing close to Fair Isle. All 19 people on board were rescued safely.

CHC said it was suspending operations using helicopters of the same type.

Bristow and Bond have now also delayed operations of EC 225 and L2 Super Pumas, during the investigation.

The Unite union said there was a growing fear among offshore workers over helicopter safety.

Unite industrial officer John Taylor said: "Mercifully there were no fatalities with this latest incident."

The manufacturer, Eurocopter, said it had full confidence in the aircraft.

A spokesman for Bristow Helicopters said: "The safety of our passengers

### Top Stories



Tories to 'curb human rights cases'

PM: Troops face generational battle

Man jailed over bogus bomb detectors

Thai police parade murder suspects

HK protesters threaten talks boycott **NEW**

### Features



#### Feline view

How do domestic cats really see the world?



#### The Pope's calling

Is Pope Francis the moderniser progressives hope for?



#### Wake-up call

Why British volunteers are hastening to help combat Ebola



#### Marooned baboon

Meet Robinson - the loneliest monkey in Africa



#### 7 days quiz

What's the only question Prince designed to answer in a Q&A?

### Related Stories

▶ Rescued workers: 'Pilots were amazing'

Flights suspended after ditching

'False warning' led to ditching



### Most Popular

Shared Read Video/Audio

Aids origin 'was 1920s Kinshasa' 1

Burmeses killed Britons in Thailand' 2



# 🔥 Applications of WSN



Distributed



Rotating



Embedded

# 🔥 Wireless HUMS

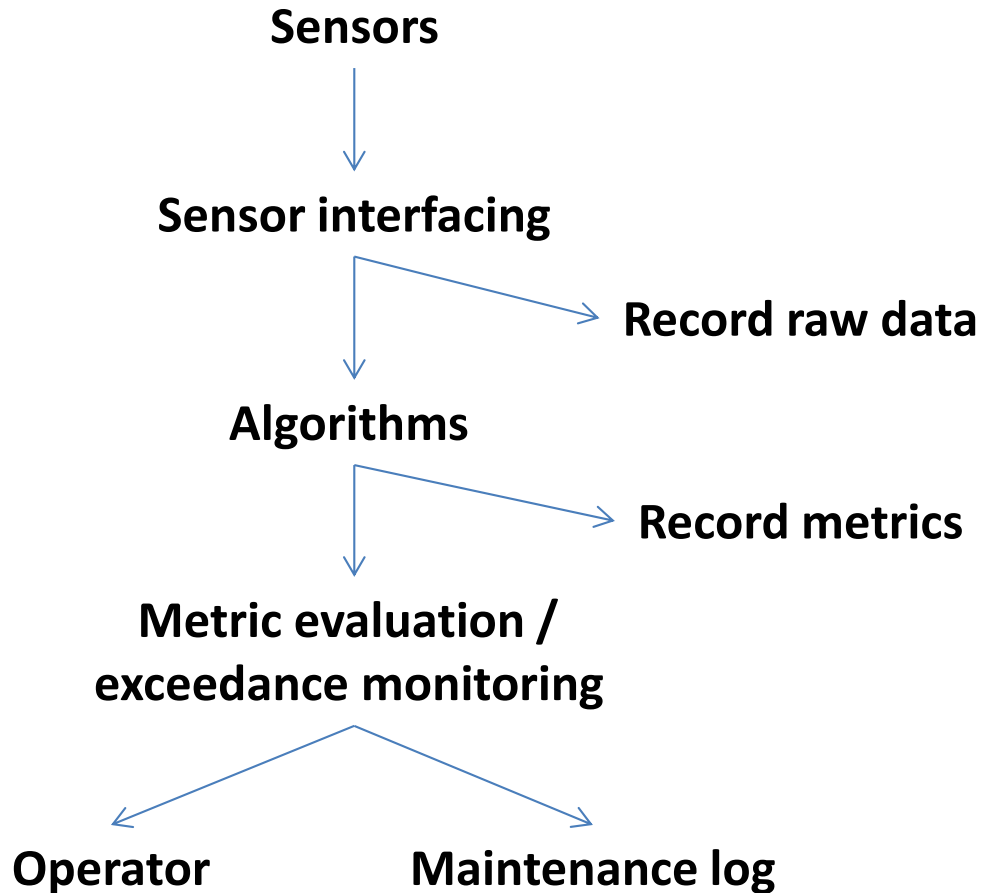





Operation;

- Periodically take several seconds of data.
- Perform some signal processing on the wireless node
- Transmit metrics or data





# Wireless HUMS

- What can we do and what can't we do COTS?
  - Miniature sensors / transducers 
  - Processing / microcontrollers 
  - Data memory 
  - Wireless data transfer 
  - Powering 



# 🔥 Powering options

## Stored energy

- Batteries
- Supercapcitor



Maxwell

## Remote power

- RF power transfer
- Inductive coupling



MESA

## Energy harvesting

- Solar
- Vibration

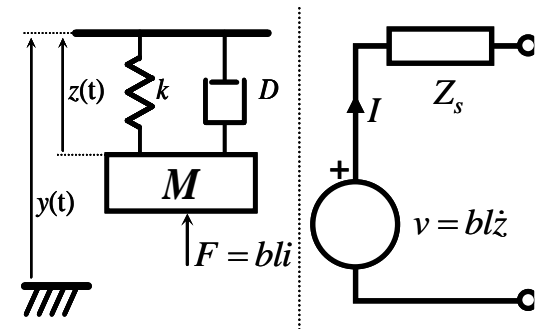

# WISD Project (2005-8)

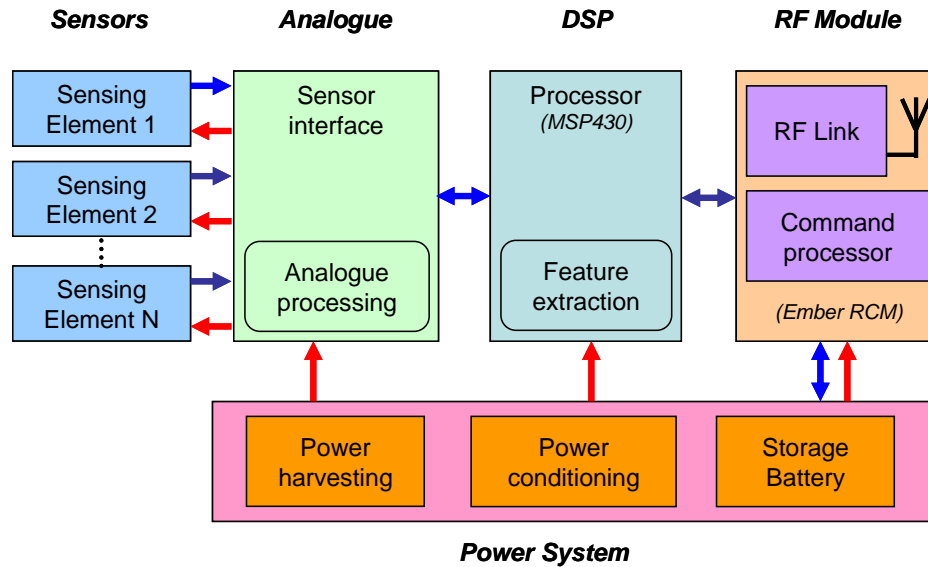

- Ultra low power sensor interfaces
- Mixed analogue/digital processing
- Energy harvesting
- Tethered flight trial



# RTVP project (2010-14)

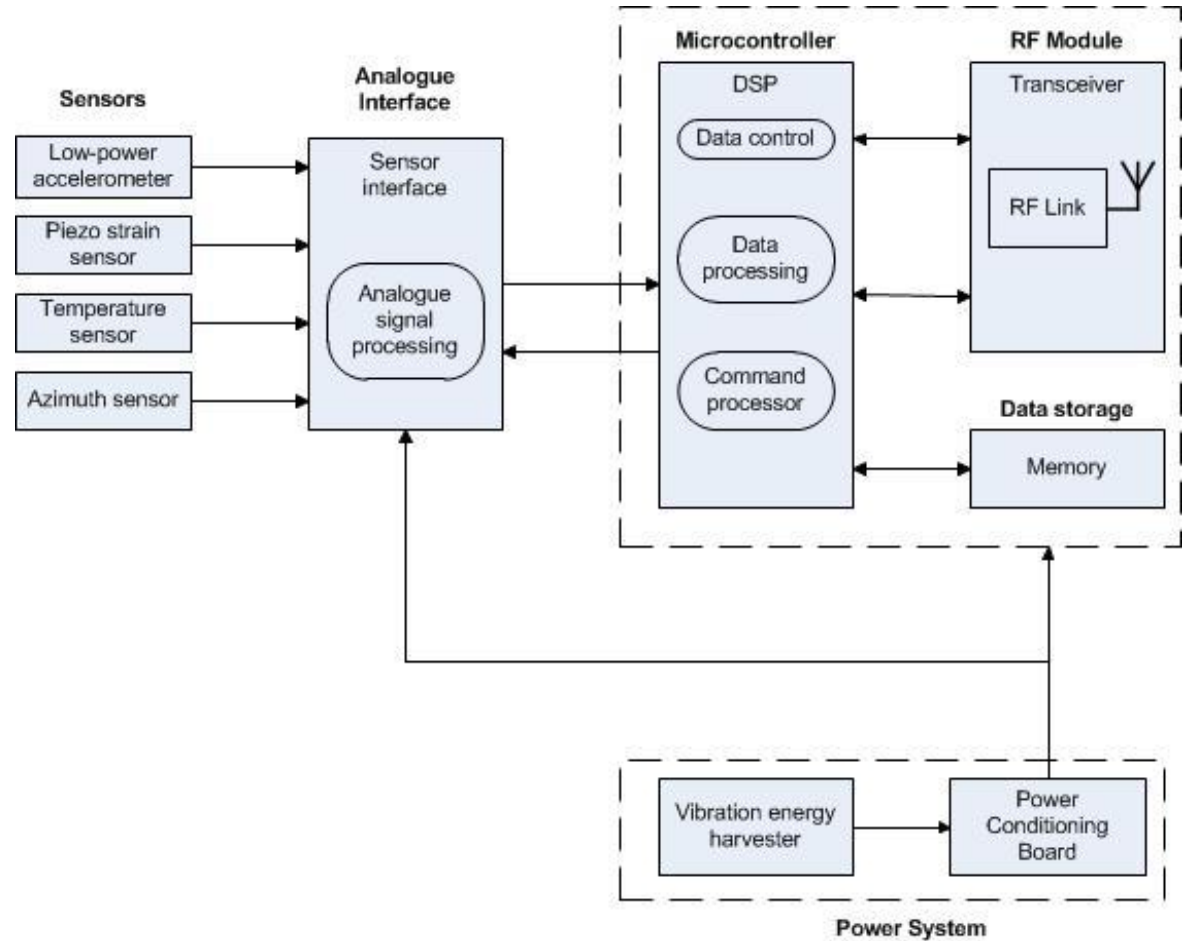

# RTVP power demand profile

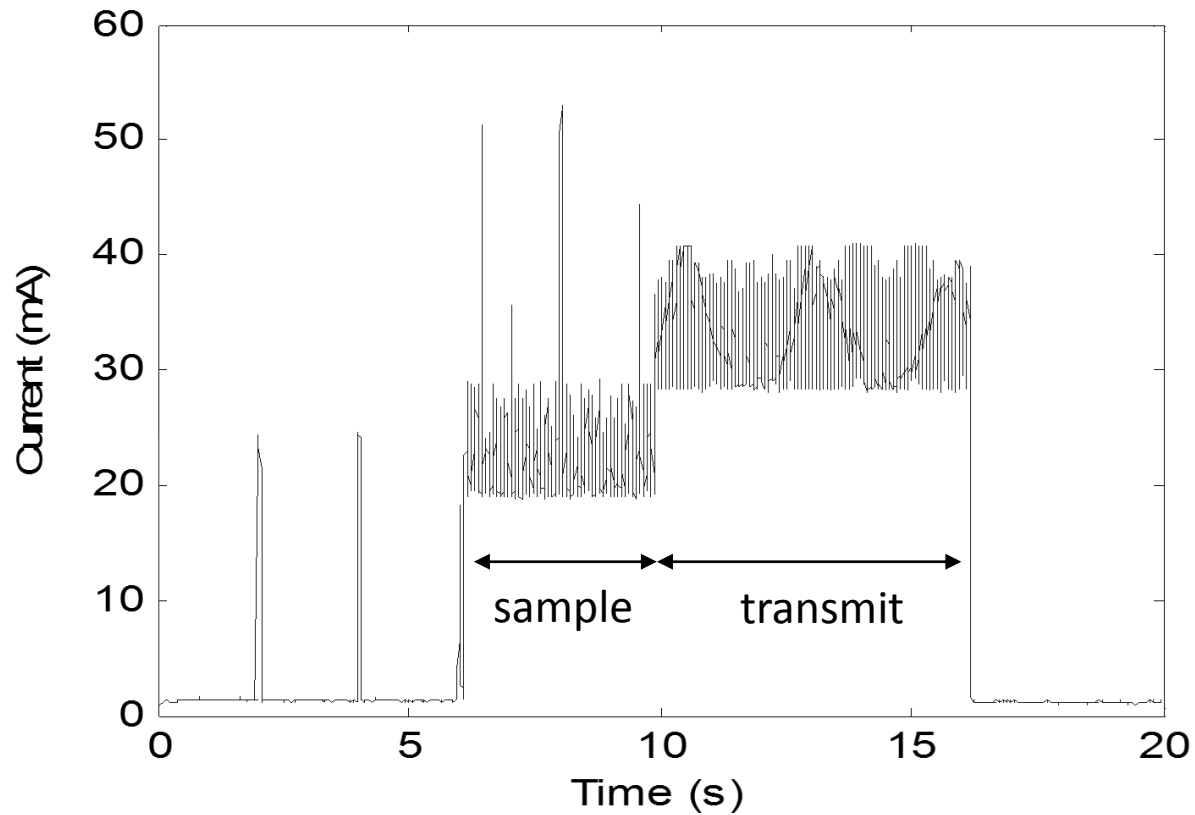

Average power when active, listening

~ 3 mW

Average power during sampling/TX

~90 mW

## ✦ Lifetime estimation constraints - battery

- Design life  $> 1000$  flight hours
- Assume node can sleep with zero power consumption between flights
- 1 sampling/processing event every minute
- Consumption  $\sim 17$  Wh  
(average power  $\sim 17$  mW)



## 🔥 High capacity cells



- Based on nominal capacity, a single 'c' size lithium thionyl chloride cell will suffice
- 45 g, 26 ml



# Capacity e-rating

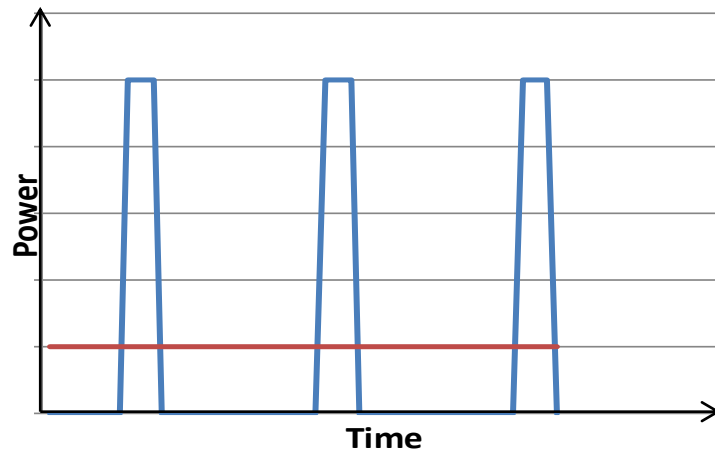

- Many so-called ‘low power’ systems are just a heavily duty cycled ‘ordinary’ systems
- From a power supply design this is the worst of all worlds – high power capability *and* low losses.
- Temperature extremes also reduce available capacity





## 🔥 High capacity cells



- De-rated for temperature and pulsed load, 4 are required
- 180 g, 104 ml



## Batteries suitable for the rotor head

- Several objections could be raised against the use of thionyl chloride on the rotor head.
  - Simply too much energy stored with potential to burn/explode
  - The environment is too extreme - exposure to high forces/temperature ranges etc.



# 🔥 Aerospace cells



- Lithium metal oxide, aerospace use in guided missiles etc. has capacity around  $\frac{1}{4}$  of thionyl chloride
- TLM 'AA' cells ~48? = 960g, 421ml?



# 🌟 Vibration harvesting

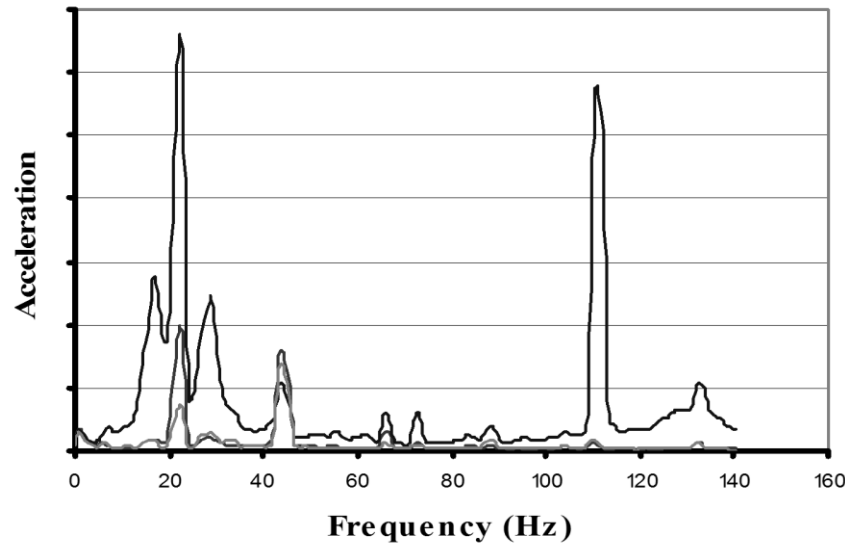

- Helicopters are a good application for energy harvesting:
  - Fixed frequencies
  - Right magnitude
- Ideally suited to electromagnetic harvesters with conventional construction.
- 10 gram mass, 20 Hz @ 1 g, 10 mm travel  $\approx$  30 mW



# 🔥 Prototype device

- Produces ~50 mW from most energetic flight condition
- 120 g, 90 ml

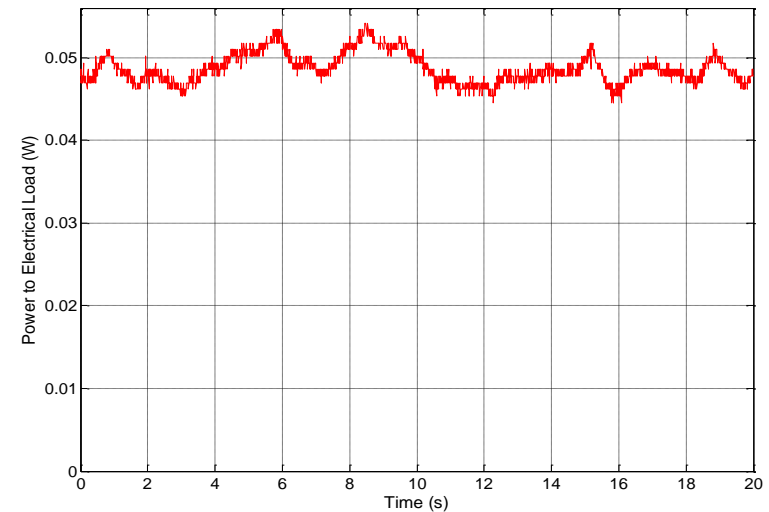
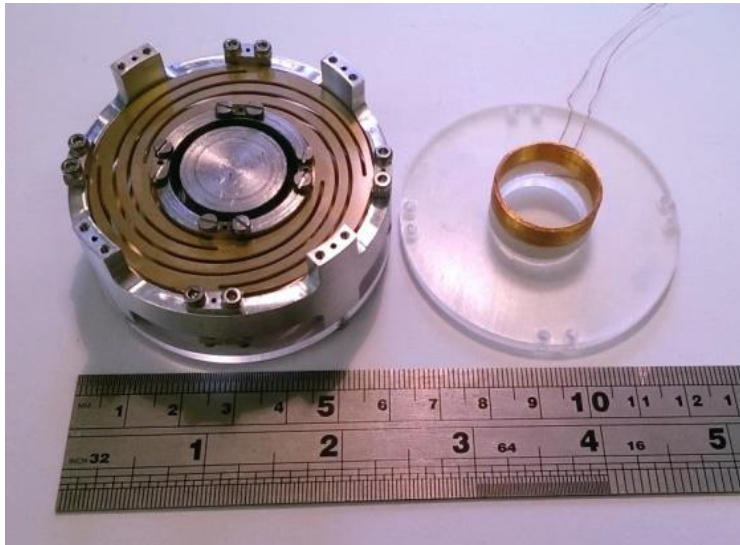
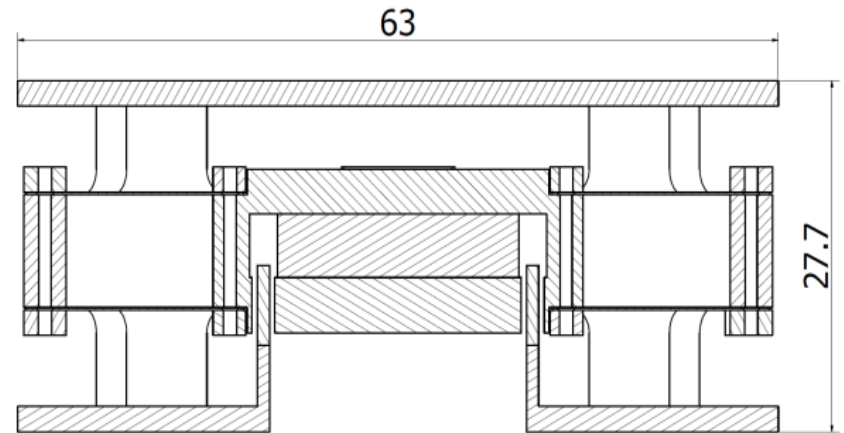

# 🔥 Required power system

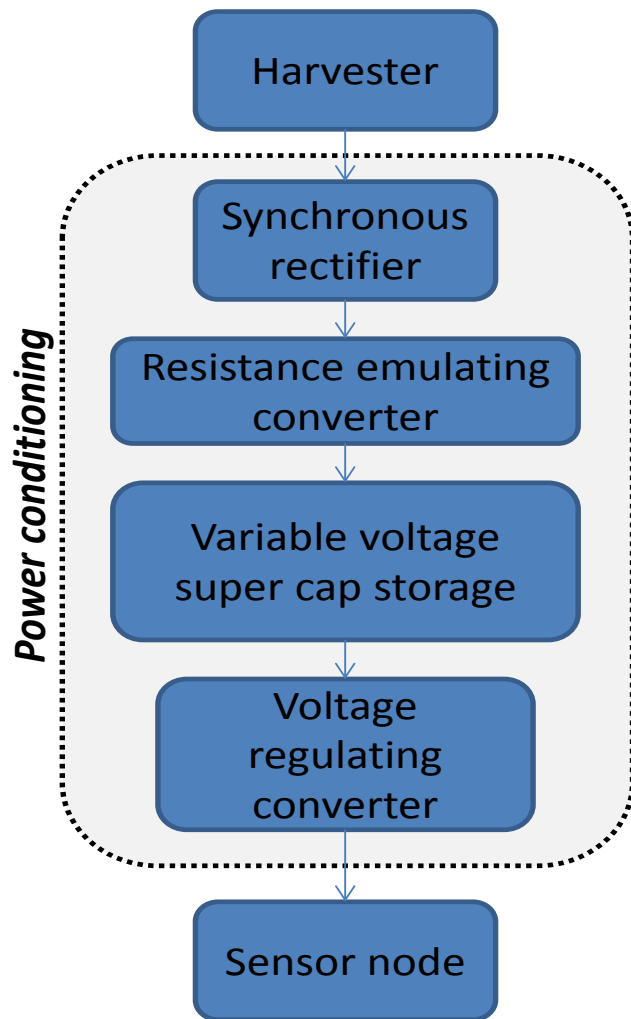

- Complexity of power system can reduce power available by 10's %

# 🔥 Operating profile

- Accumulation of harvested energy determines operation profile
- Typically a longer initial charge period is required from powered down state

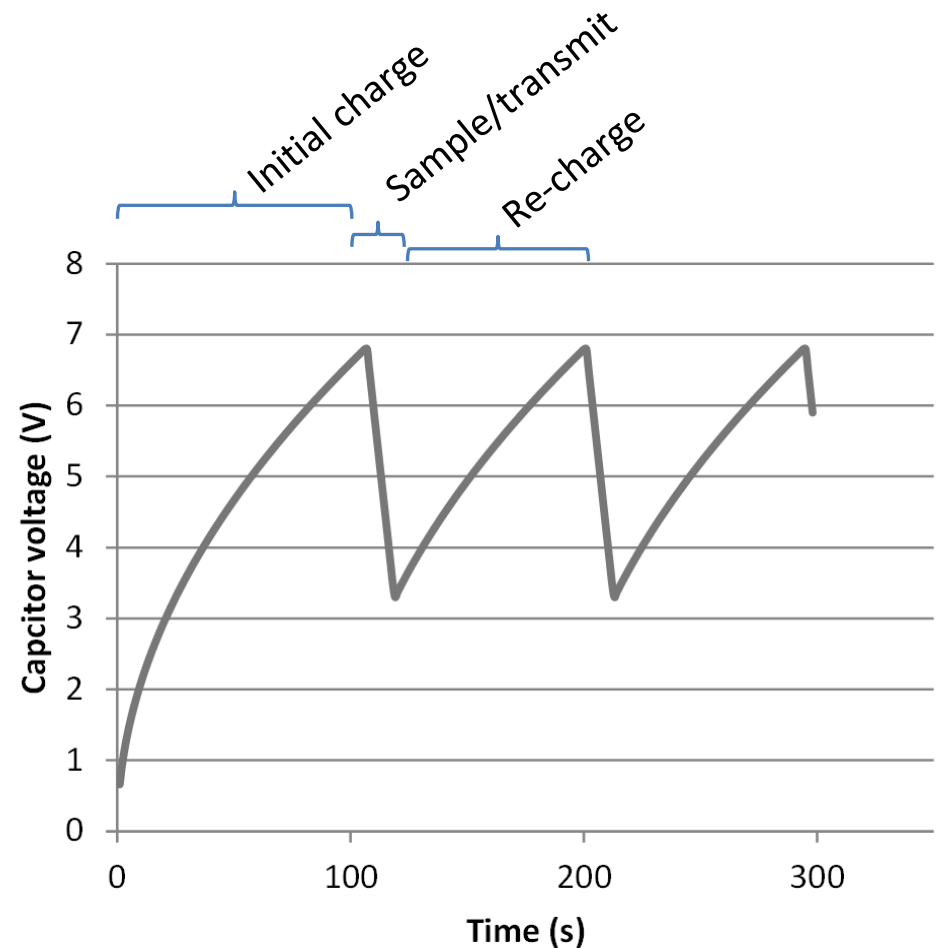

# Conclusions

- Battery size scales with total energy - the power demand and length of time between maintenance
- Harvester size scales with just the power demand as energy is infinite
- Both approaches may have issues with initial start up





# Conclusions

- HUMS require a specification for hardware that requires 10's mW with current technologies
- For lifetime ~ 1000 hrs and one sampling operation in 60 seconds, both solutions have similar volumes/masses
- Both solutions have presented unforeseen problems in physical testing



Thank you for your attention

